



# TAI-SAW TECHNOLOGY CO., LTD.

No. 3, Industrial 2nd Rd., Ping-Chen Industrial District,  
Taoyuan, 324, Taiwan, R.O.C.

TEL: 886-3-4690038 FAX: 886-3-4697532

E-mail: [tstsales@mail.taisaw.com](mailto:tstsales@mail.taisaw.com) Web: [www.taisaw.com](http://www.taisaw.com)

## Product Specifications Approval Sheet

Product Description: SAW Filter 931.25 MHz SMD 3.0x3.0 mm (BW=12.5 MHz)

TST Part No.: TA2400A

Customer Part No.: \_\_\_\_\_

|                             |
|-----------------------------|
| Customer signature required |
| Company: _____              |
| Division: _____             |
| Approved by : _____         |
| Date: _____                 |

Checked by: \_\_\_\_\_ David Chang *David*

Approved by: \_\_\_\_\_ Andy Yu *Andy Yu*

Date: \_\_\_\_\_ 2018/04/18

1. Customer signed back is required before TST can proceed with sample build and receive orders.
2. Orders received without customer signed back will be regarded as agreement on the specifications.
3. Any specifications changes must be approved upon by both parties and a new revision of specifications shall be released to reflect the changes.



# TAI-SAW TECHNOLOGY CO., LTD.

No. 3, Industrial 2nd Rd., Ping-Chen Industrial District,  
Taoyuan, 324, Taiwan, R.O.C.

TEL: 886-3-4690038 FAX: 886-3-4697532

E-mail: [tstsales@mail.taisaw.com](mailto:tstsales@mail.taisaw.com) Web: [www.taisaw.com](http://www.taisaw.com)

## SAW Filter 931.25 MHz

MODEL NO.: TA2400A

REV. NO.:1

### A. MAXIMUM RATING:

1. Input Power Level: 10 dBm
2. DC Voltage : 3 V
3. Operating Temperature: -40 °C to +85 °C
4. Storage Temperature: -40 °C to +85 °C
5. Moisture Sensitivity Level: Level 1(MSL1)

RoHS Compliant  
Lead free  
Lead-free soldering

Electrostatic Sensitive Device (ESD)

### B. ELECTRICAL CHARACTERISTICS:

| Item   | Unit  | Min. | Typ.   | Max. |
|--|-------|------|--------|------|
| Center frequency <b>Fc</b>                     | MHz   | -    | 931.25 | -    |
| Insertion Loss (925~937.5 MHz) <b>IL</b>       | dB    | -    | 1.2    | 2.5  |
| Amplitude Ripple (925~937.5 MHz)               | dB    | -    | 0.3    | 1.6  |
| VSWR (925~937.5 MHz)                           | -     | -    | 1.5    | 2.2  |
| <b>Attenuation</b> (Reference level from 0 dB) |       |      |        |      |
| 10 ~ 880 MHz                                   | dB    | 31   | 36     | -    |
| 880 ~ 910 MHz                                  | dB    | 7    | 21     | -    |
| 955 ~ 960 MHz                                  | dB    | 24   | 48     | -    |
| 960 ~ 2500 MHz                                 | dB    | 25   | 36     | -    |
| Temperature coefficient of frequency           | ppm/k | -    | -36    | -    |

### C. MEASUREMENT CIRCUIT:

HP Network analyzer

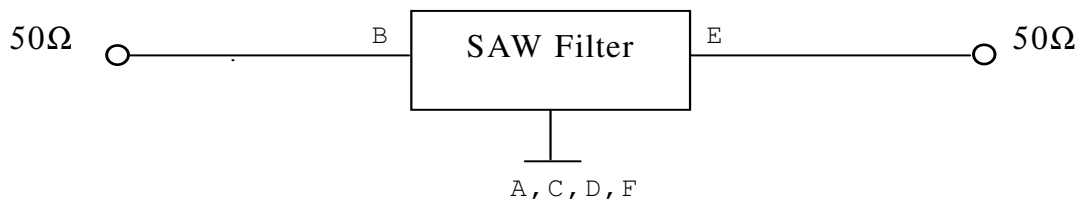

**D. OUTLINE DRAWING:**

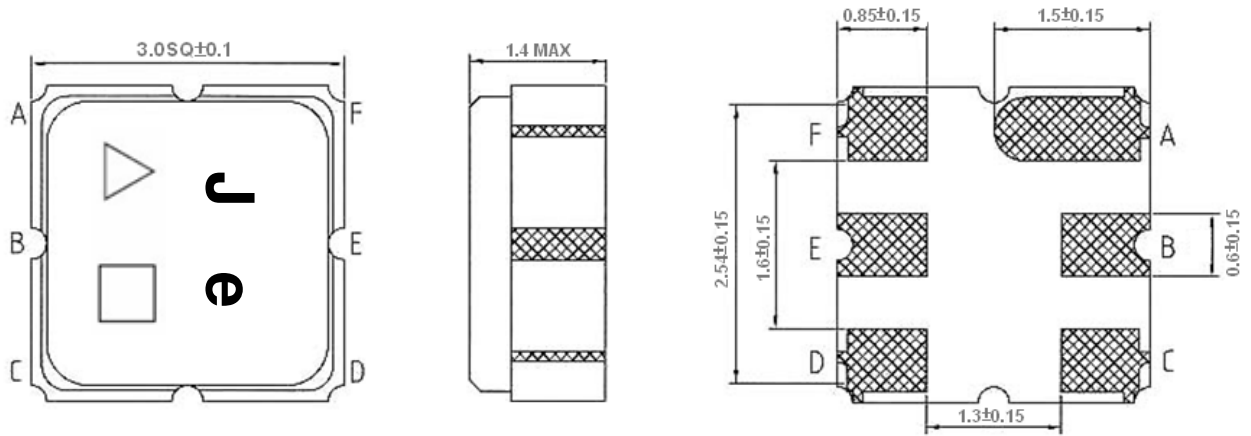

**B: Input**

**E: Output**

**A, C, D, F: Ground**

**Unit: mm**

**△ : Year Code (2011->1, 2012->2, ..., 2019->9, 2020->0)**

**□ : Date Code**

**Date Code Table:**

|      |      |      |      |      |      |      |      |      |      |      |      |      |
|------|------|------|------|------|------|------|------|------|------|------|------|------|
| WK01 | WK02 | WK03 | WK04 | WK05 | WK06 | WK07 | WK08 | WK09 | WK10 | WK11 | WK12 | WK13 |
| A    | B    | C    | D    | E    | F    | G    | H    | I    | J    | K    | L    | M    |
| WK14 | WK15 | WK16 | WK17 | WK18 | WK19 | WK20 | WK21 | WK22 | WK23 | WK24 | WK25 | WK26 |
| N    | O    | P    | Q    | R    | S    | T    | U    | V    | W    | X    | Y    | Z    |
| WK27 | WK28 | WK29 | WK30 | WK31 | WK32 | WK33 | WK34 | WK35 | WK36 | WK37 | WK38 | WK39 |
| a    | b    | c    | d    | e    | f    | g    | h    | i    | j    | k    | l    | m    |
| WK40 | WK41 | WK42 | WK43 | WK44 | WK45 | WK46 | WK47 | WK48 | WK49 | WK50 | WK51 | WK52 |
| n    | o    | p    | q    | r    | s    | t    | u    | v    | w    | x    | y    | z    |

**E. PCB Footprint:**

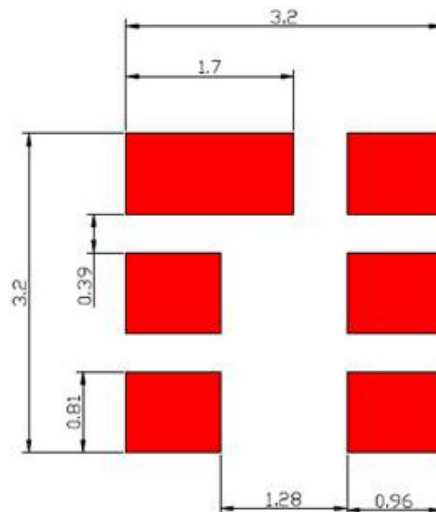

## F. Frequency Characteristics:

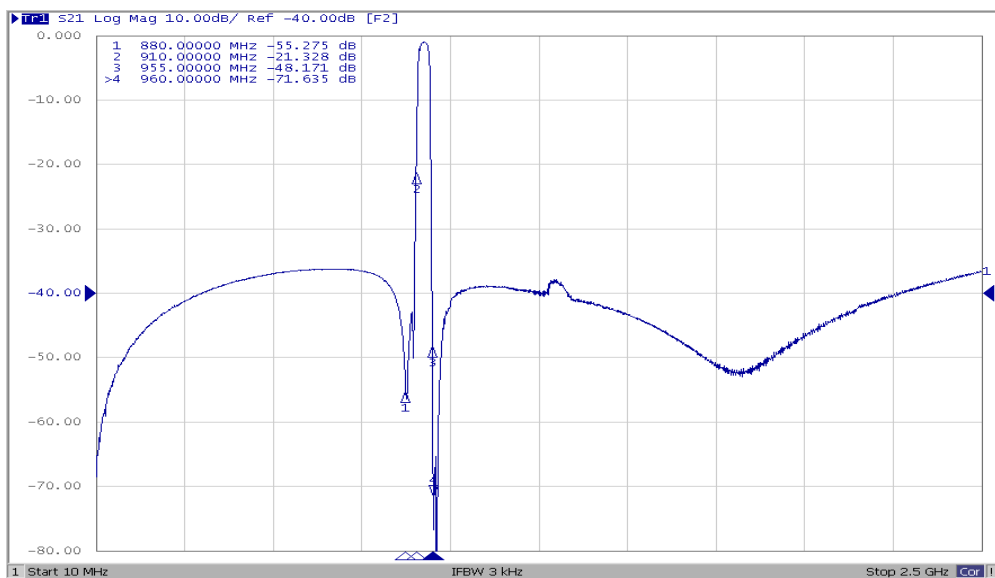
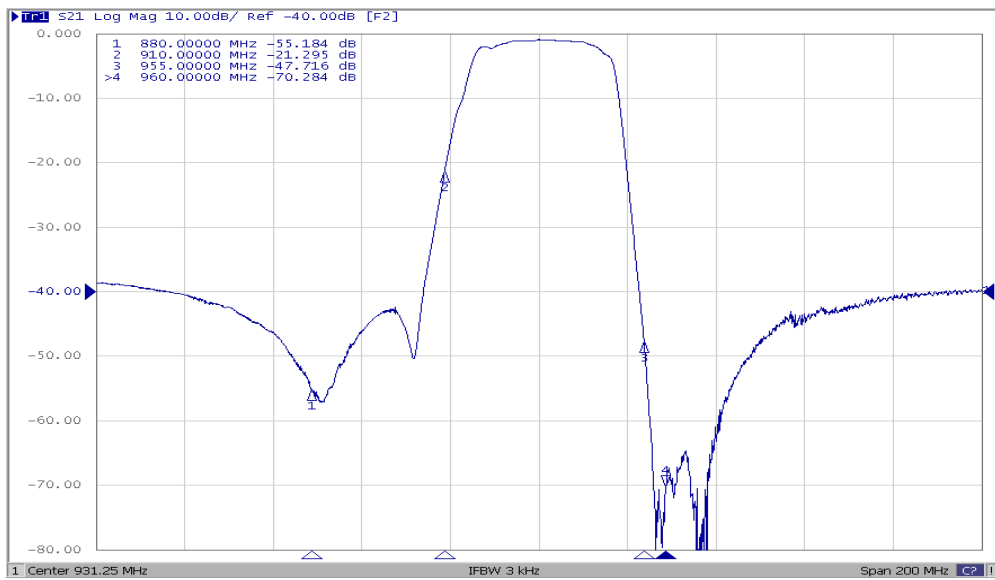
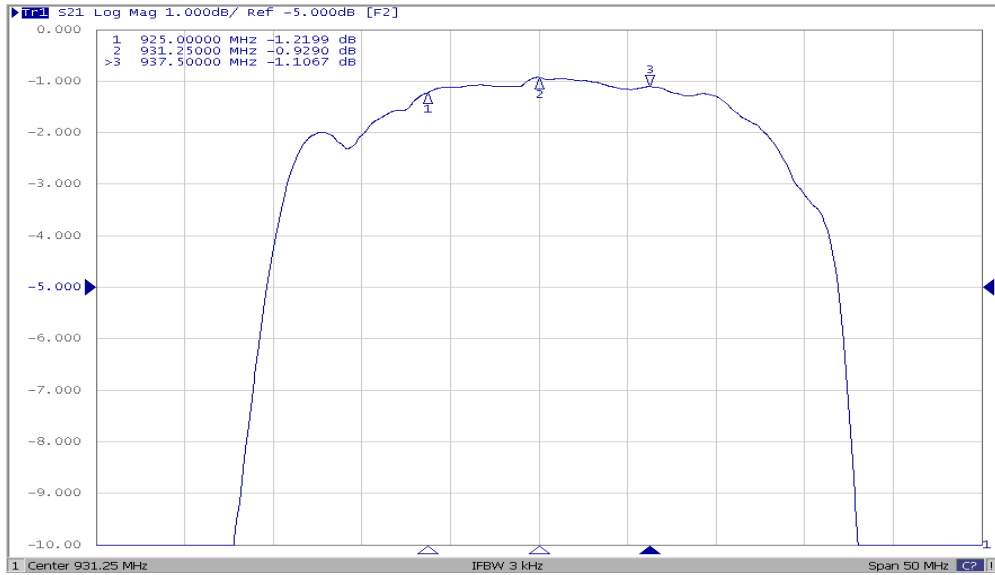

# Reflection Functions:

## S11

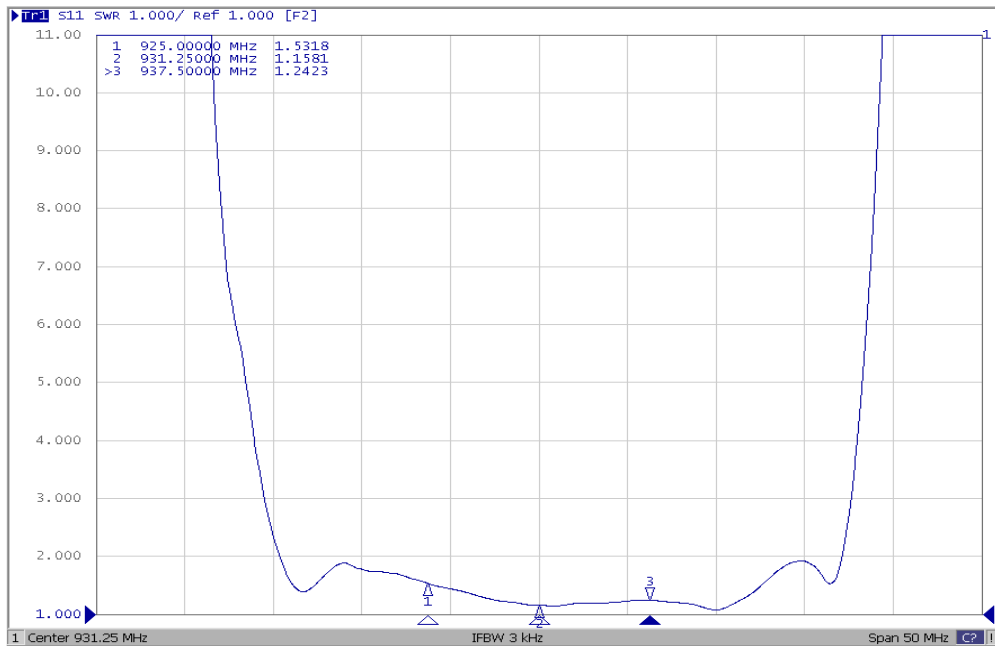

## S22

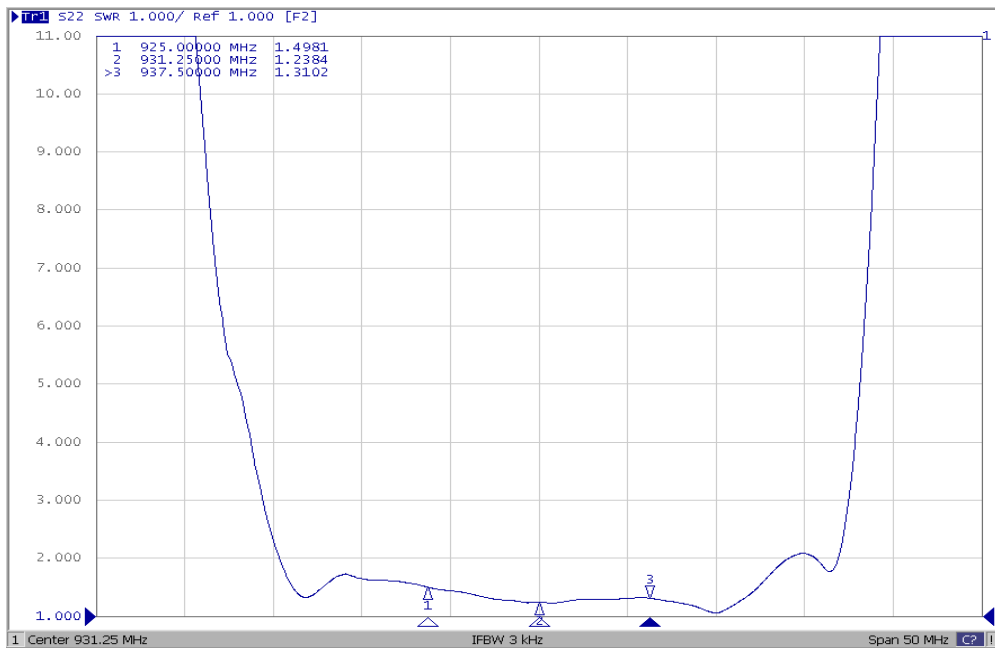

**G. PACKING: (Ref. WI-75M03)**

**1. REEL DIMENSION**

**(Please refer to FR-75D10 for packing quantity)**

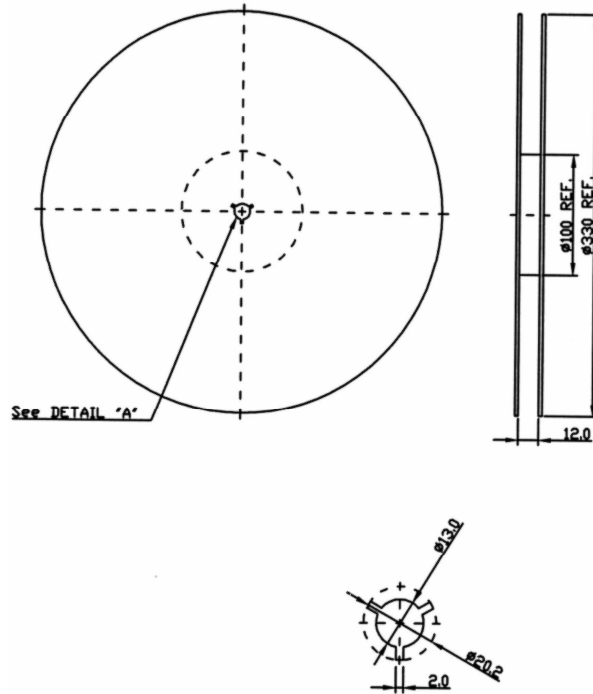

**2. TAPE DIMENSION**

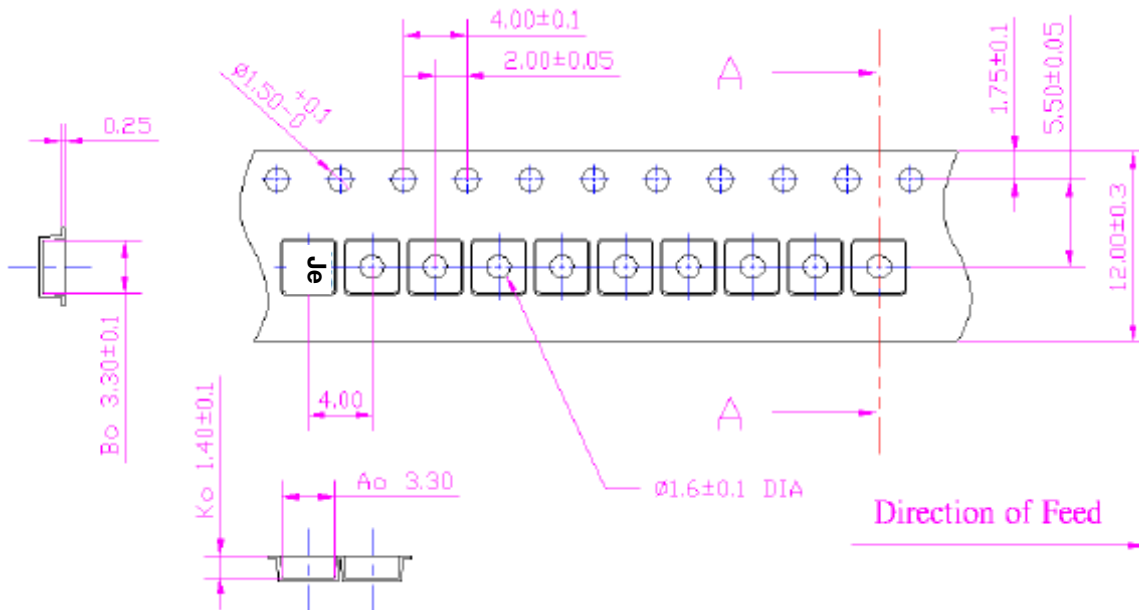

### H. Recommended Reflow Profile:

1. Preheating shall be fixed at 150~180°C for 60~90 seconds.
2. Ascending time to preheating temperature 150°C shall be 30 seconds min.
3. Heating shall be fixed at 220°C for 50~80 seconds and at 260°C+0/-5°C peak (20~40sec).
4. Time: 2 times.

